

NOT RELEASED FOR PRODUCTION

Revision History				
EC No	REV	Date	Description	Approvals
NA	X00	3/25/24	Created Dwg.	JE

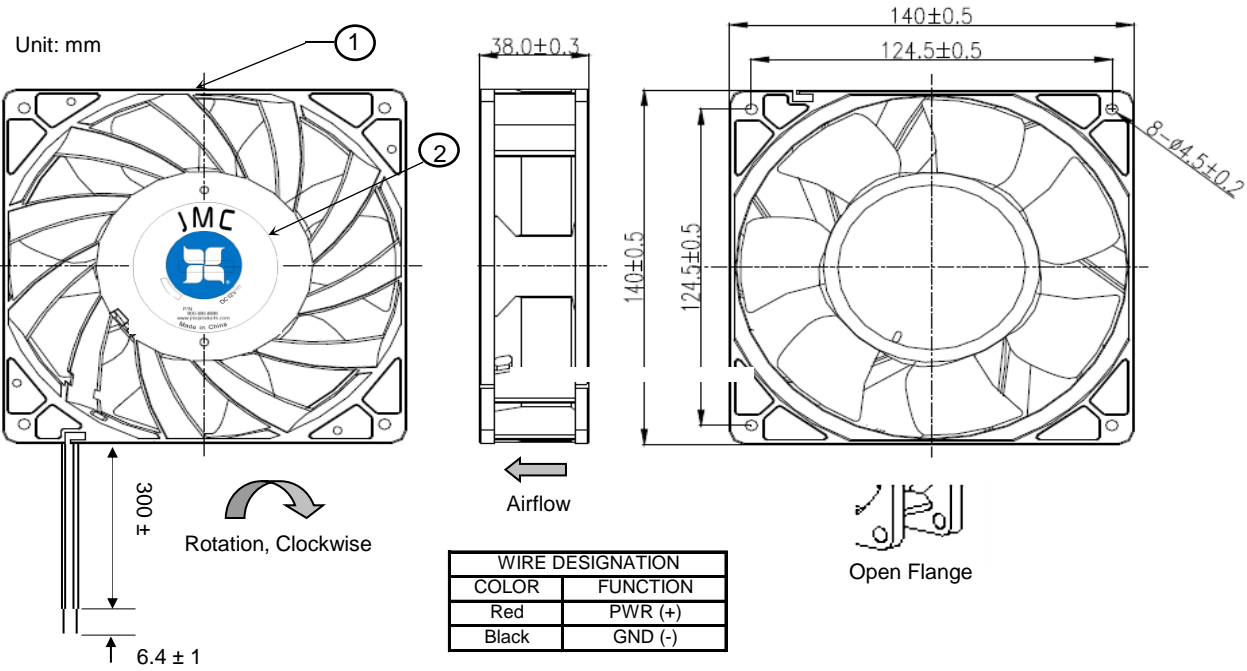

1. THIS FAN AND ALL OF ITS COMPONENTS COMPLY WITH THE REQUIREMENTS OF RoHS DIRECTIVE EU 2015/863.
2. BASE MODEL FAN - ANY CHANGES TO SPECIFICATION REQUIRES NEW PART NUMBER AND DRAWING.

WIRE DESIGNATION	
COLOR	FUNCTION
Red	PWR (+)
Black	GND (-)

	ITEM	SPECIFICATION	UNITS / NOTES
MECHANICAL	Speed	5400 +/- 10%	RPM at 12 Vdc
	Airflow	280	CFM in Free Air
	Static Pressure	1.42	Inch, H ₂ O
	Bearing Type	Ball, Dual	N/A
	Operating Temp	(-)10 to 60	Deg C
	Storage Temp	(-) 40 to 70	Deg C
	Noise Level	62.0	dBA Max at 1M
PHYSICAL	Blade Material	UL 94V-0	N/A
	Frame Material	UL 94V-0	N/A
	Wire Size	24	AWG
	Wire Type	UL1007	N/A
	Wire Assembly	First Slot	N/A
	Regulatory Approvals	Pending	N/A
	Net Weight	TBD	Grams Approx.
ELECTRICAL	Operating Voltage	10.8-12.6	Vdc
	Start up Voltage	10.8	Vdc
	Start up PWM duty cycle	NA	%
	Rated Current	2.6 (3.0 Max)	Amp
	Input Power	31.2 (36.0 Max)	Watts
	Tach Output	NA	Pulses/Rev
	Polarity Protection	Yes	N/A
Motor Protection	Yes	Type 2, AR	

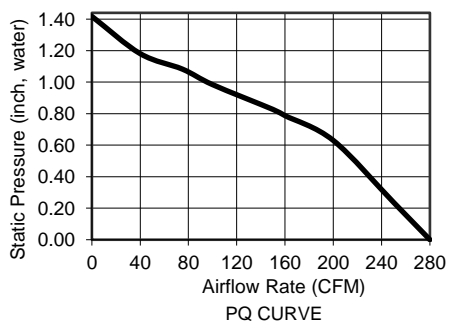

2	1	Logo Label	L14000B0003	JMC
1	1	Fan Model	1438 - 12	JMC
Item	Qty	Description	Part Number	MFG
Austin Texas, USA			Fan, 140 x 38 FV, 12Vdc, Dual Ball, Base Model	
Dong Guan, PRC				
Drawn By		The Fan Company	Drawing Number	Rev
S. Apsangi				
Engineer		Scale: None	14000B0003	X00
J. Elmo				

PROPRIETARY NOTE

This document is the property of JMC products and contains sensitive and confidential information. Neither this document nor any information it contains may be reproduced or distributed, without written permission by JMC products.