

Revision History				
EC No	REV	Date	Description	Approvals
NA	X00	5/31/2008	Created Drg.	SA

NOTES

- THIS FAN AND ALL OF ITS COMPONENTS COMPLY WITH THE REQUIREMENTS OF RoHS DIRECTIVE 2002/95/EC
- BASE MODEL FAN - ANY CHANGES TO SPECIFICATION REQUIRES NEW PART NUMBER.

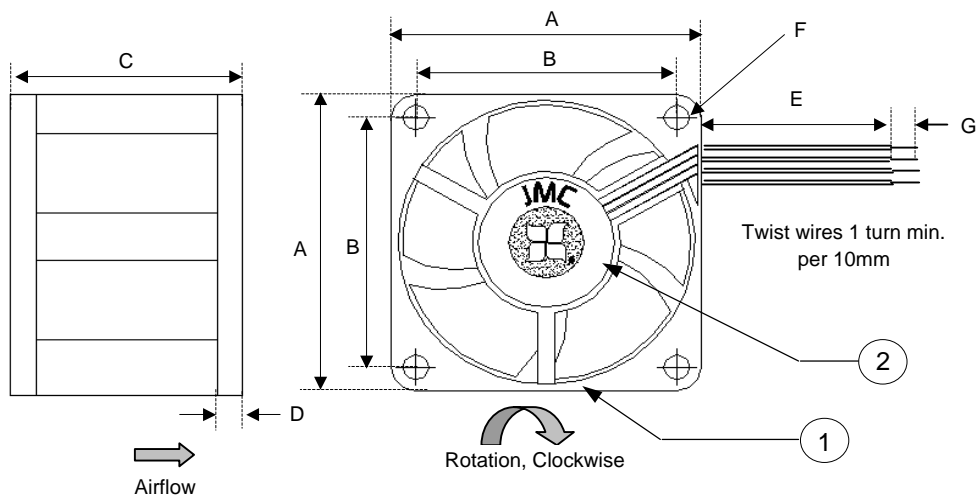

WIRE DESIGNATION	
Wire Color	Function
Black	GND (-)
Yellow	PWR (12Vdc)
Green	TACH
Blue	PWM

All Dimensions in mm	
A	38 +/- 0.5
B	32 +/- 0.3
C	28 +/- 0.5
D	3.0 +/- 0.3
E	300 +/- 25
F	4 X 3.5 Dia +/- 0.3
G	6.4 +/- 1.0

Frame Type (Closed Barrel)

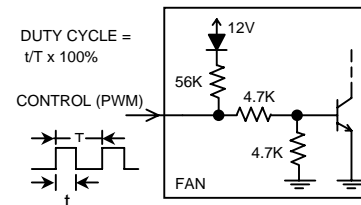
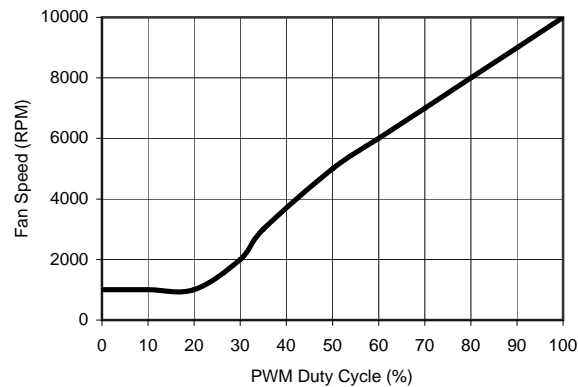
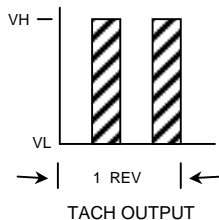

FRONT END PWM CIRCUIT

	ITEM	SPECIFICATION	UNITS / NOTES
MECHANICAL	Speed	10000 +/- 10%	RPM at 12 Vdc
	Airflow	10.0	CFM in Free Air
	Static Pressure	0.33	Inch, H ₂ O
	Bearing Type	Dual Ball	N/A
	Operating Temp	(-)10 to 70	Deg C
	Storage Temp	(-)40 to 70	Deg C
	Noise Level	38.0	dBA Max at 1M
PHYSICAL	Blade Material	UL 94V-0	N/A
	Frame Material	UL 94V-0	N/A
	Wire Size	24	AWG
	Wire Type	UL 1061	N/A
	Wire Assembly	First Slot Only	N/A
ELECTRICAL	Regulatory Approvals	UL CUL TUV	N/A
	Net Weight	TBD	Grams
	Operating Voltage	10.0 - 13.2	Vdc
	Starting Voltage	NA	Vdc
	Starting PWM Duty Cycle	30.0	%
	Rated Current	0.30	Amp
	Input Power	3.60	Watts
	Tach Output	2	Pulses/Rev
	Polarity Protection	Yes	N/A
	Motor Protection	By Auto restart	N/A

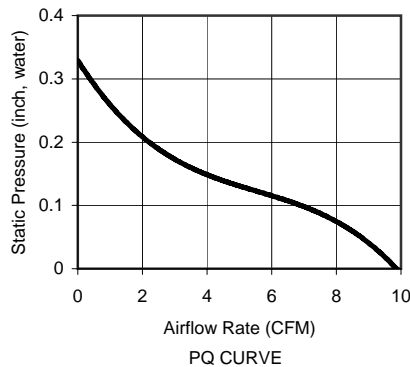

2	1	Logo Label	L03800B0004	JMC
1	1	Fan Model	3828 - 12	JMC
Item	Qty	Description	Part Number	MFG
Austin Texas, USA Dong Guan, PRC				Fan, 38 X 28 mm, 12Vdc, PWM, Base Model
Drawn By S. Apsangi		Size A1	Drawing Number 03800B0004	Rev X00
Engineer J Elmo		Scale: None		Sheet 1 of 1

PROPRIETARY NOTE

This document is the property of JMC products and contains sensitive and confidential information. Neither this document nor any information it contains may be reproduced or distributed, without written permission by JMC products.