

REVISION HISTORY				
EC NUMBER	DATE	DESC.	REV.	APPROVED

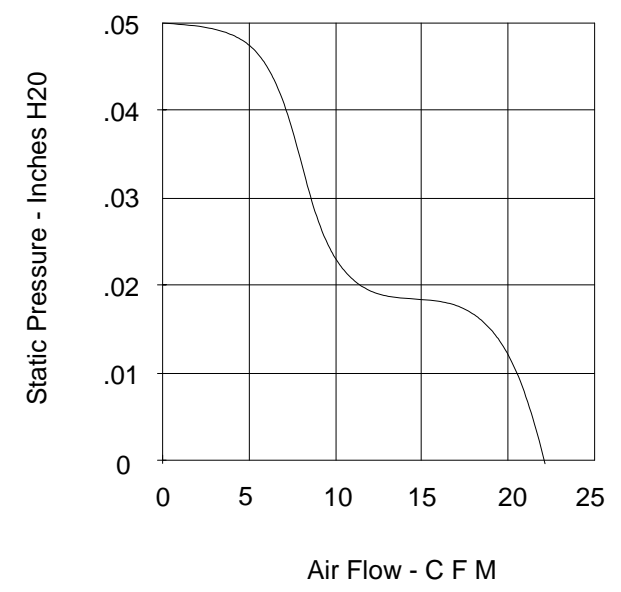
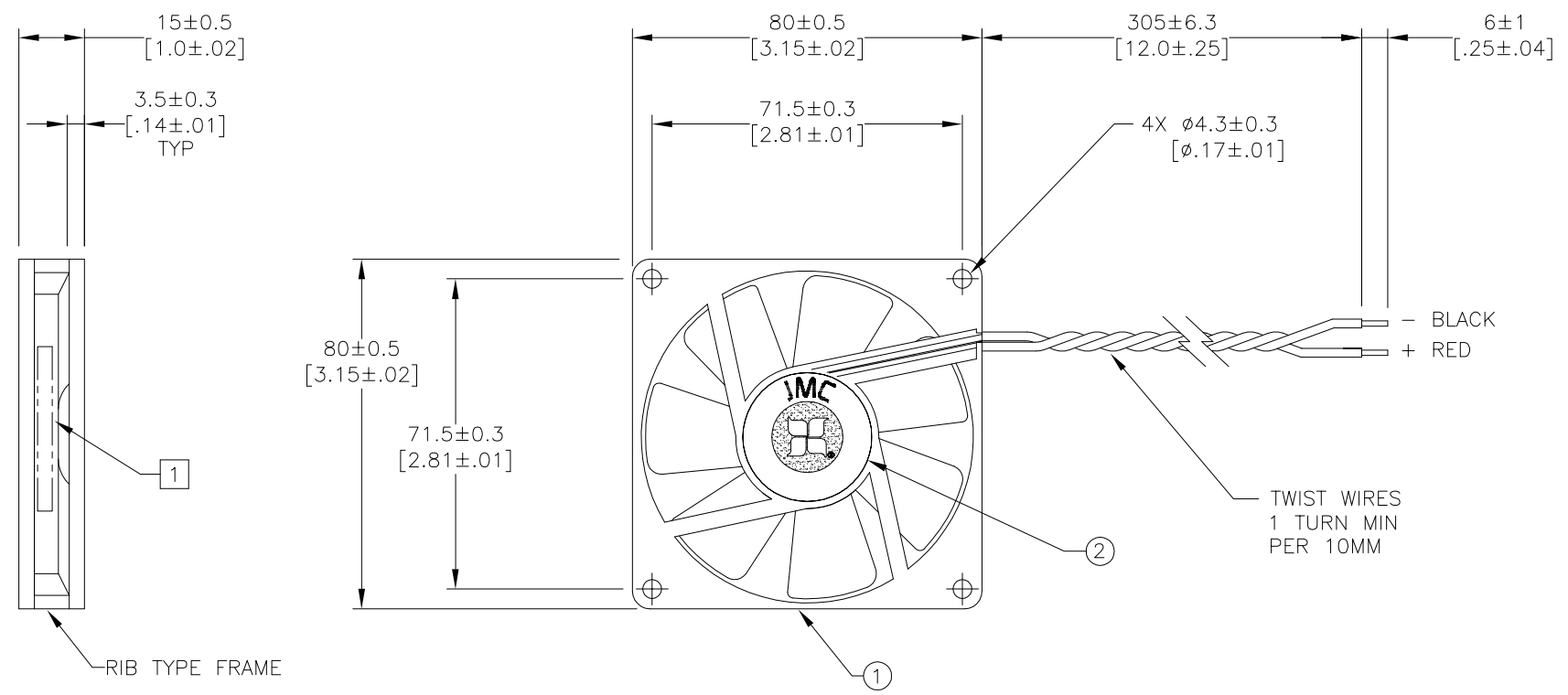

	ITEM	SPECIFICATION	UNITS/NOTES
MECHANICAL	SPEED	2000 ± 10%	RPM AT 12 VDC
	AIRFLOW	23.3	CFM IN FREE AIR
	STATIC PRESSURE	.05	INCHES H <sub>2</sub> O
	BEARING TYPE	BALL, DUAL	-
	OPERATING TEMP	-10 TO 70	°C
	STORAGE TEMP	-40 TO 70	°C
	NOISE LEVEL	21.41	dBA MAX AT 1M
	L10 TEST DATA	75,000	HOURS
PHYSICAL	BLADE MATERIAL	UL 94V-0	-
	FRAME MATERIAL	UL 94V-0	-
	WIRE SIZE	26	AWG
	WIRE TYPE	UL 1007	-
	REGULATORY APPROVALS	UL CUL TUV	-
	NET WEIGHT	55	GRAMS
ELECTRICAL	OPERATING VOLTAGE	6.0-13.8	VDC
	STARTING VOLTAGE	6.0	VDC
	RATED CURRENT	.09	AMP
	INPUT POWER	1.08	WATT
	TACH OUTPUT	N/A	PULSES/REV
	MOTOR PROTECTION	POLARITY, AUTO RESTART	-

- NOTES:
- FAN LABEL MUST BE MARKED WITH DRAWING NUMBER AND REVISION TO FLAT AREA ON THE SIDE OF THE FAN AS INDICATED USING SMALLEST LEGIBLE CHARACTER HEIGHT.
  - THIS FAN INCORPORATES PANTHER TECHNOLOGY.

**PROPRIETARY NOTE**  
 THIS DOCUMENT IS THE PROPERTY OF JMC PRODUCTS OF AUSTIN, TEXAS AND CONTAINS SENSITIVE AND CONFIDENTIAL INFORMATION. NEITHER THIS DOCUMENT NOR ANY INFORMATION IT CONTAINS MAY BE REPRODUCED, DISTRIBUTED OR TRANSMITTED IN ANY FASHION, FOR ANY PURPOSE, EITHER IN WHOLE OR IN PART, WITHOUT EXPRESS WRITTEN PERMISSION BY AUTHORIZED OFFICIALS OF JMC PRODUCTS. THIS DOCUMENT MUST BE RETURNED ON DEMAND UPON COMPLETION OF ORDER OR UPON REQUEST.

2	1	LOGO LABEL	300010-16	JMC
1	1	FAN MODEL	8015-12LB [Q]	JMC
ITEM	QTY	DESCRIPTION	PART NUMBER	MANUFAC.
		PRIMARY UNITS IN MILLIMETERS ALTERNATE UNITS [ ] IN INCHES		
		<b>JMC</b> AUSTIN, TEXAS		
		TOLERANCE UNLESS OTHERWISE SPECIFIED X.X±0.3 [.01] X.XX±0.13 [.005]		
		THIRD ANGLE PROJECTION		
DRAWN BY		DATE	SIZE A2	DRAWING NO. 802210Q-0
ENGINEER		DATE	SCALE: NONE	REV. PDF
			SHEET 1 OF 1	

REV. PDF  
DRAWING NO. 802210Q-0